

RDX
ACTICAL

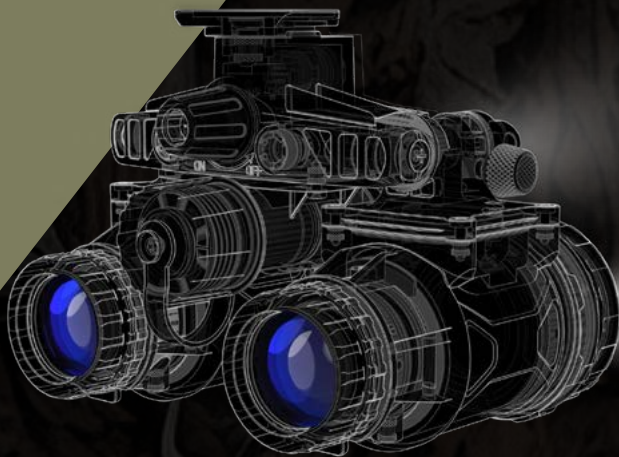

RNV-31



RJX
ACTICAL

▼ TABLE OF CONTENTS

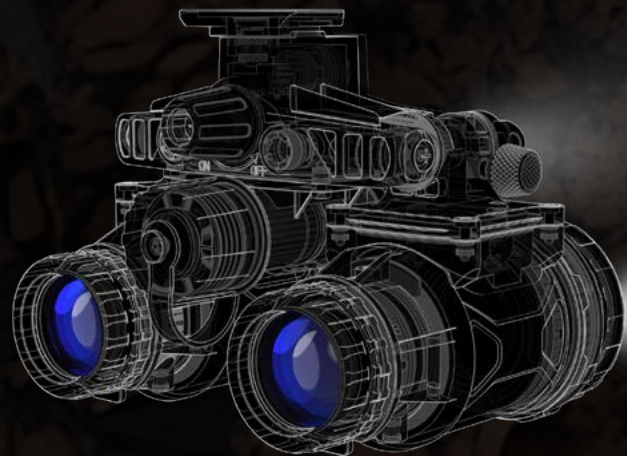

01
PRODUCT OVERVIEW

02
PRODUCT PARAMETERS

03
PACKING LIST

04
PRODUCT APPEARANCE

05
DEVICE MODES

06
POWER SUPPLY

07
EXTERNAL BATTERY
COMPARTMENT

08
POWER ON/OFF

09
CONTROLS AND
INDICATORS

10
PRODUCT
MAINTENANCE

11
PRODUCT TROUBLE
SHOOTING

12
LEGAL AND REGULATORY
INFORMATION

01 PRODUCT OVERVIEW

The RNV-31 is a self-contained night vision device that enables night vision capabilities by using ambient light from the night sky. Typically, this is the moon, star, and/or sky glow.

Optically, RNV-31 is made up of two sets of objective lenses image intensifier and eyepiece lens. The objective lens collects light reflected from the moon, stars, or night sky, inverts the image, and focuses that image on the image intensifier. The image intensifier converts the captured light into a visible image and reinverts the image, which you can then view through the eyepiece lens.

The RNV-31 has an internal IR LED for operating when no ambient light is available. By switching the unit to the infrared (IR) mode, the IR LED produces an artificial light source that is invisible to the human eye but is detected by the RNV-31. The unit uses light produced by the IR LED to reveal images hidden in the dark.

02 PRODUCT PARAMETERS

| Specs | |
|-----------------------------|--|
| Model | RNV-31 |
| Magnification | 1X |
| Objective Lens | 25mm; F1.2 |
| FOV | 40° |
| Focus Range | 0.25m ~ +∞ |
| Eye relief | 25mm |
| Diopter adjustment | -4 ~ +2 |
| LED indicator (with in FOV) | IR illuminator Flip-up off Side flip-up off BSP bright source protection Low battery indicator |
| Tube compatibility | NNVT、10160、11769 EGAC moved |
| IR illuminator | 850nm |
| Battery type | 1 AA battery |
| Operating time | 20h |
| Ingress protection | 10m |
| Dimensions | 110mm×97mm×90mm |
| Operating temperature | -40°C ~ +50°C |
| Weight | 500g ± 5% |

03 PACKING LIST

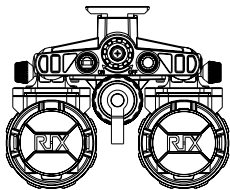

RNV-31 Device



Thermal Fusion
Pendant Adapter



Long eyeshade

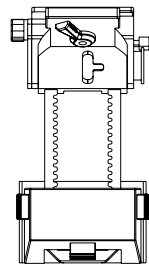

Helmet Bracket(L4G24)
(optional)

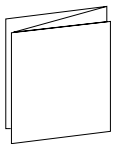

User manual



Portable bag

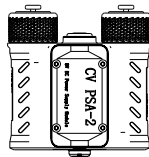

Battery pack(optional)

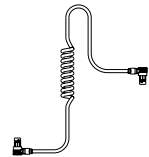

Cables (optional)

04 PRODUCT APPEARANCE

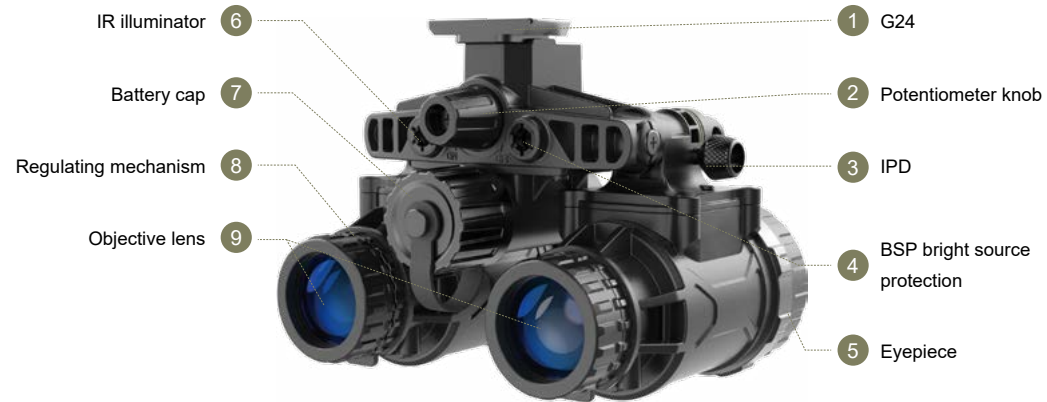

05 DEVICE MODES

Helmet Mode

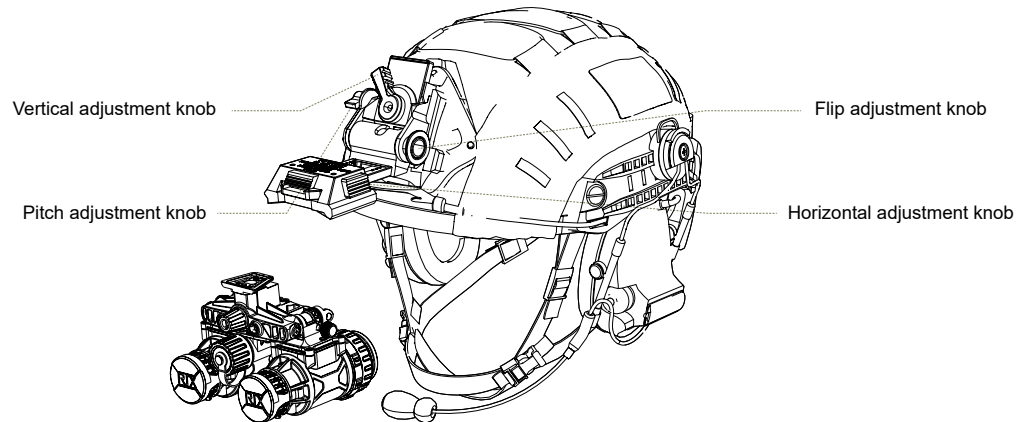

NOTE

A clear image can be acquired only when both the objective lens and the eyepiece are correctly focused.

Installation of Thermal Fusion Pendant Adapter (Achieve Fusion with J-C):

1. Secure the Thermal Fusion Pendant Adapter to the bottom of the objective lens with 2 M2x5 screws. Verify the alignment, screw in the bolts, and tighten.
2. After sliding J-C into the Thermal Fusion Pendant Adapter, listen for a "click" sound, indicating that J-C is securely locked into the Thermal Fusion Pendant Adapter.

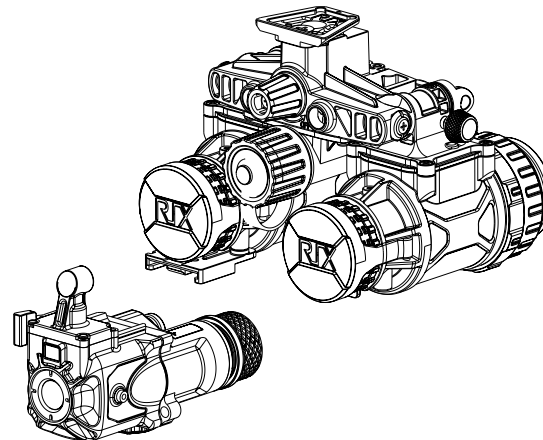

▼06 POWER SUPPLY

Install the storage battery following the below procedures:

1. Unscrew the battery cap.
2. Insert the AA battery (please pay attention to the polarity marked on the device).
3. Tighten the battery cap.

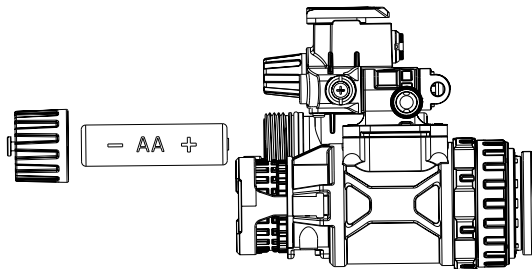

WARNING

- » Please remove the battery if the device is not in use for long periods of time.
- » Don't power the device with a modified or damaged battery.

NOTE

The decrease in battery pack capacity under sub-zero temperatures is normal and not a factory defect.

▼07 EXTERNAL BATTERY COMPARTMENT

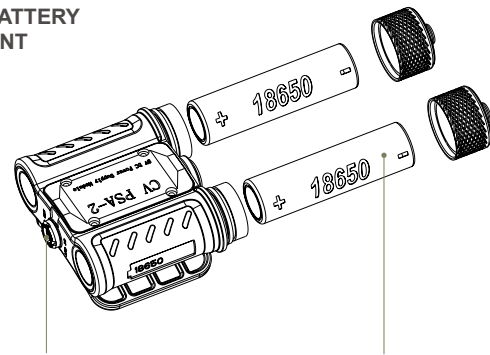

Align The Marked Points for Installation

Battery Installation Diagram

1. Install batteries as shown.
2. Power on the battery compartment before connecting to the whole machine, then connect the battery compartment and RNV-31 with the cable. Turn on or off the power to the battery box, as shown in the figure (long press).

NOTE

Please use 3.7V standard 18650 batteries. Incorrect installation can cause short circuits and equipment damage.

3. When the battery compartment is powered on, it displays the power (green, blue, and red prompts). During the process of using the battery compartment, click to display the current power.

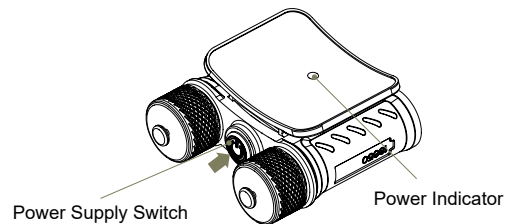
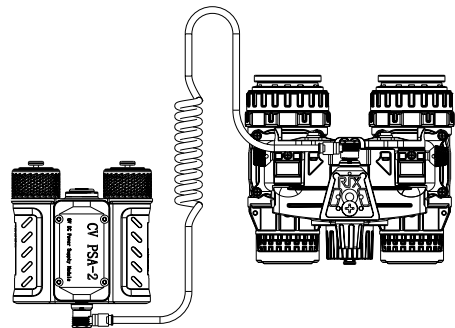

NOTE

The red light indicates that the battery is low and needs to be replaced in time.

▼08 POWER ON/OFF

POWER ON

1. Turn clockwise, and when you hear a "click," turn on the power.
2. After power is applied, rotate the potentiometer gain adjuster.

POWER OFF

Counter-clockwise rotation, and when you hear a "click," turn off.

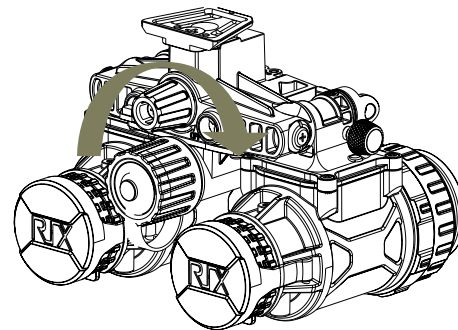

09 CONTROLS AND INDICATORS

» Flip function

Press the potentiometer knob three times consecutively (with no more than 1 second between presses).

ON: blue light blinks twice (500 ms/time).

OFF: blue light flashes twice (250 ms/time).

Flip >90° to turn off the power.

The device automatically powers on after returning to its initial state.

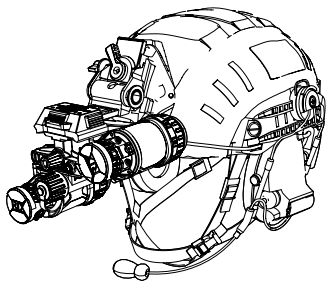

MONOCULAR GOGGLES POSITION

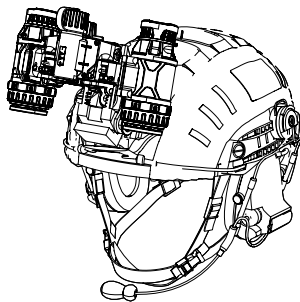

STOWED POSITION

» BSP bright source protection function

Press the potentiometer knob five times in a row (the interval between two times is not more than one second)

ON: Green light blinks twice (500 ms/time).

OFF: Green light flashes twice (250 ms/time).

If you continuously exceed the illumination level (IC reading of 120) for 1 minute, the CRT will power off.

If it needs to be turned on, it must be restarted.

» IR Illuminator function

Press and hold the potentiometer for 2 seconds to turn the IR illuminator on/off. When the status indicator light remains continuously red, it indicates that the infrared illuminator is turned on.

NOTE

When more than two functions are executed, there is a priority control: the latter can interrupt the former, and if the latter operation is completed, the interrupted former continues to execute.

» Battery Level Detection

When the battery voltage falls below 1.15V, the red status indicator will blink.

» Auto sleep mode

The image intensifier tube will automatically turn off if the device remains stationary for over 3 minutes. After the image intensifier tube is turned off, it will be reactivated if there is a change in the device's posture.

▼10 PRODUCT MAINTENANCE

NOTE

- » The binocular night vision device is a precision optoelectronic instrument and must be handled with care.
- » Do not scratch the outer surface of the lens or touch it with your fingers.
- » Do not wipe the shield with wet lens paper or when the shield is wet, or the coating will be damaged.

Avoid scratching the lens or leaving fingerprints on the optics when cleaning the unit; improper cleaning may damage the optics.

Follow the instructions below to clean the lens:

1. Do not use abrasive materials such as paper or abrasive brushes as this may scratch or damage the lens.
2. Wipe only when there is visible contamination on the surface.
3. The preferred method of cleaning lens material is optical grade cloth purified water (isopropyl alcohol).

11 PRODUCT TROUBLE SHOOTING

| MALFUNCTION | PROBABLE CAUSE/TEST/INSPECTION | CORRECTIVE ACTION |
|--|--|--|
| The device will not power on. | 1.Check that batteries are installed in the correct direction and whether the battery power is sufficient or not. 2.Inspect the battery cover for damage, wear, or deformities. | 1.Replace the battery or install the battery correctly. 2.Clean the battery cover threads. |
| The battery cap is difficult to dismount. | Check whether the battery cover is damaged. | Please contact the technical support engineer if the battery cover is damaged. |
| The IR illuminator will not turn on. | Turn on the IR illuminator in the dark area and see if the observed scene is illuminated. | Please contact the technical support engineer if the IR illuminator cannot be turned on. |
| The LED indicator will not display. | Visual check | Please contact the technical support engineer. |
| Poor image quality. | 1.Check the focus of the objective lens or eyepiece. 2.Check whether there is fog or dirt on the lens. 3.Check whether the optical component is damaged. | 1.Adjust the focus of the objective lens and eyepiece. 2.If the image quality is still poor, please contact customer support. 3.Please contact the technical support engineer. If it is damaged, contact technical support engineer. |
| The eyepiece ring cannot be adjusted. | Check whether the eyepiece ring is bent or broken. | If it is damaged, contact customer support. |
| The device does not turn off when exposed to bright light. | Perform the following test in daylight or bright indoor lighting (non-fluorescent): Place the objective cover over the objective lens and turn the unit on to see if it powers off after 60 seconds. | If it is damaged, contact customer support. |

12 LEGAL AND REGULATORY INFORMATION

1. This device complies with part 15 of the FCC Rules. Operation is subject to the following two conditions:
 (1) This device may not cause harmful interference.
 (2) This device must accept any interference received, including interference that may cause undesired operation.

2. Any Changes or modifications not expressly approved by the party responsible for compliance could void the user's authority to operate the equipment.
 EMC Class B grade

NOTE

This equipment has been tested and found to comply with the limits for a Class B digital device, pursuant to part 15 of the FCC Rules. These limits are designed to provide reasonable protection against harmful interference in a residential installation. This equipment generates, uses and can radiate radio frequency energy and, if not installed and used in accordance with the instructions, may cause harmful interference to radio communications. However, there is no guarantee that interference will not occur in a particular installation. If this equipment does cause harmful interference to radio or television reception, which can be determined by turning the equipment off and on, the user is encouraged to try to correct the interference by one or more of the

Following measures:

- Reorient or relocate the receiving antenna.
- Increase the separation between the equipment and receiver.
- Connect the equipment into an outlet on a circuit different from that to which the receiver is connected.
- Consult the dealer or an experienced radio/TV technician for help.





3

YEAR
WARRANTY
Night Vision Devices